



Moteur Vigor - BO-10



Gear Ratio 1:220
3.0~6V DC
a vide 5V 40 mA, 30 rpm
bloqué 5V 500mA

poids 36g

Gear set 1:110 et 1:55

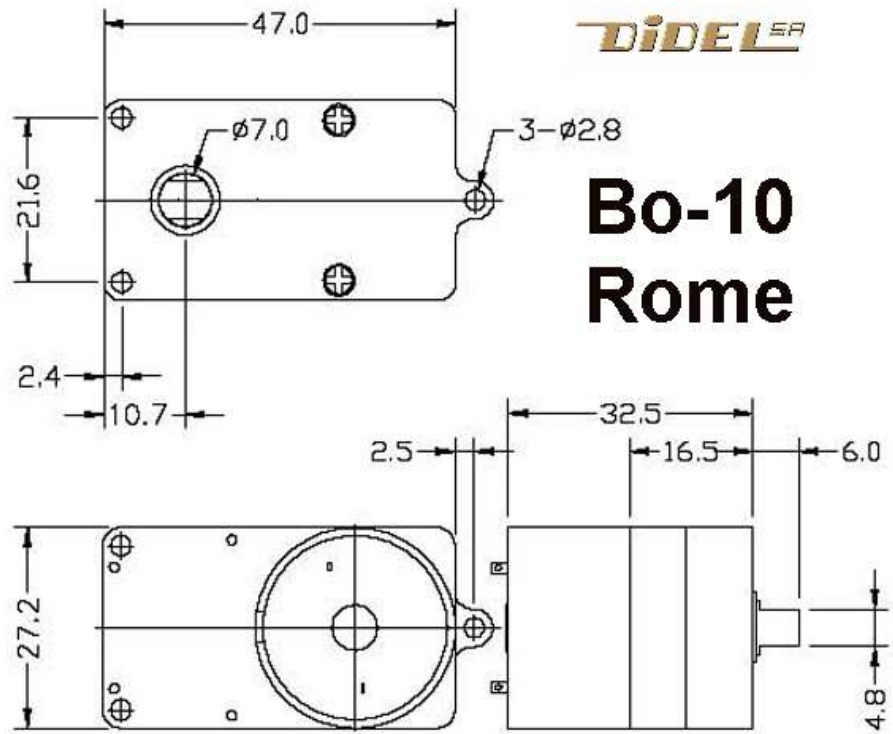

Le moteur est coincé entre 2 plaques de contreplaqué ou plastique 3mm, ou entre le circuit Smofix et la base. La largeur du robot dépend de l'arrangement des piles et du contrôleur.

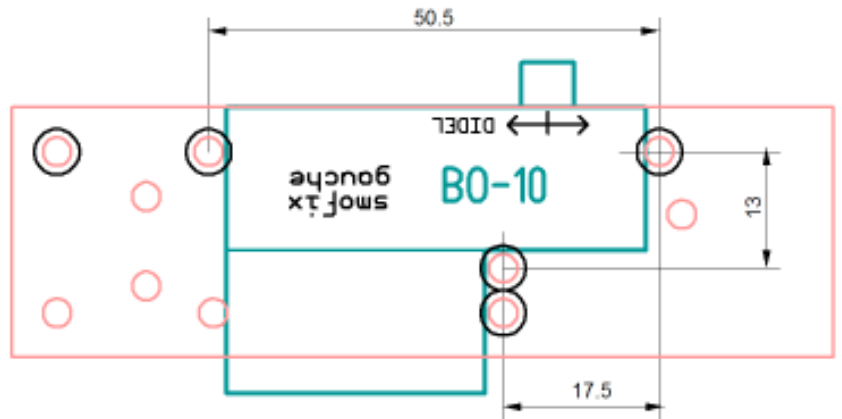
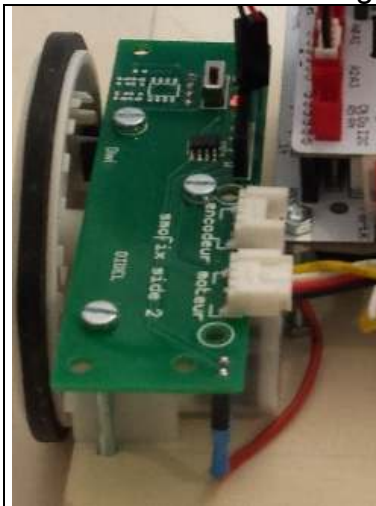

Smofix – motor Bo-10 et roues

- 2 moteurs VigorPrecision Bo10
- 6 vis M3x30
- 6 écrous M3
- 2 roues 66mm
- 2 vis PT 2.2x6.5
- 1 mini-ballcaster (pas sur la photo)

14 CHF

