

## DgAdal2C #76

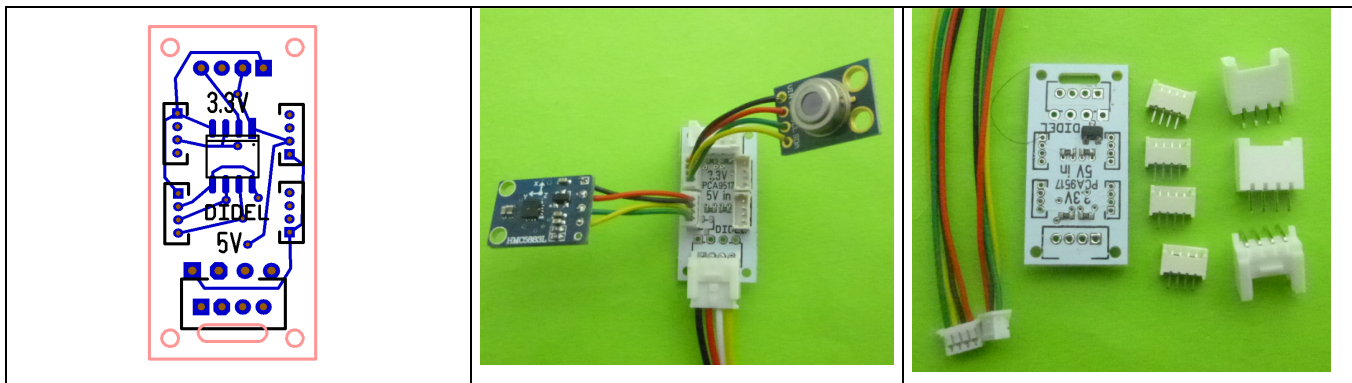

A difficulty when interfacing I2C is the two standard voltages, 5V and 3.3V, used on microcontrollers and sensor chips. The Texas Instrument PCA9517 Level-Translating I2C Bus Repeater is designed to convert from a 3V to 5V voltage to a lower voltage, 1.8 to 3V.

The DgAdal2c makes it easy to connect, and play the role of a I2C hub with 3 + 3 I2C connectors, using grove and minigrove handy miniature connectors.

Three options are possible as shown below:

- 1) You are on a 5V Arduino or other and you have to connect a 3V sensor. Usually these sensors are low power and we provide a 1303-3.3V LDO to power them (max 100mA). Just add a drop of solder to connect the 1703 output.
- 2) You are on a 3V Raspy or other and you want to connect a 5V I2C device. You need to bring the 5V.
- 3) You are on a 3V Raspy or other and you want to connect a 1.8V I2C device. The 3V side is now under 5V label and you need to bring the 1.8V., unless you change the 1703 against a 1.8V LDO.

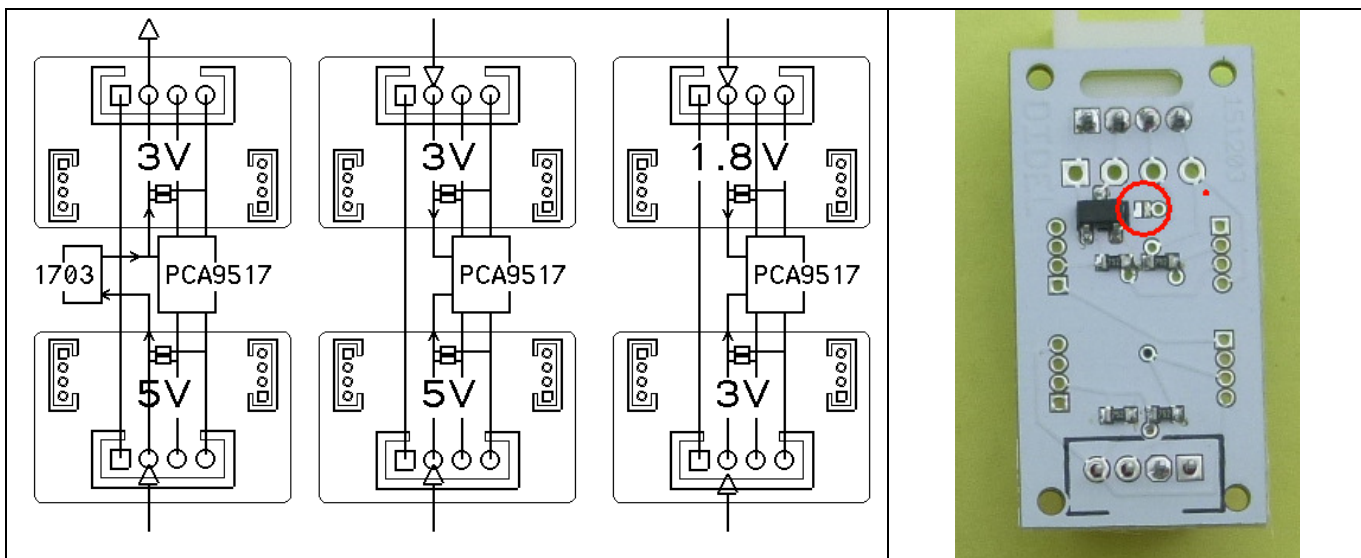

In one case, strap open, power is externally provided for both voltages, with the constraint that voltage on the "5V" side must be higher than the voltage on the "3V" side.

With the strap connected by a drop of solder, a LDO regulator MCP1703 provides 3.3V, 200mA on the "3V" side.

Miniature Molex connectors with 1.25 mm pitch are very convenient to connect breakout I2C sensors. A four wires Molex male cable is plugged on 5V or 3V side according to the sensor specifications. Be careful: pin 1 wire is red, connected to the Gnd. Pin 2 (V+) is black.

The kit includes 2 Molex cables in addition to the 4 molex connectors and three grove connectors (one is 90 degrees). SMD components are already soldered and tested.

